

***CAST STEEL GATE VALVES
ASME CLASS 600 LBS.***

FIG. VS06

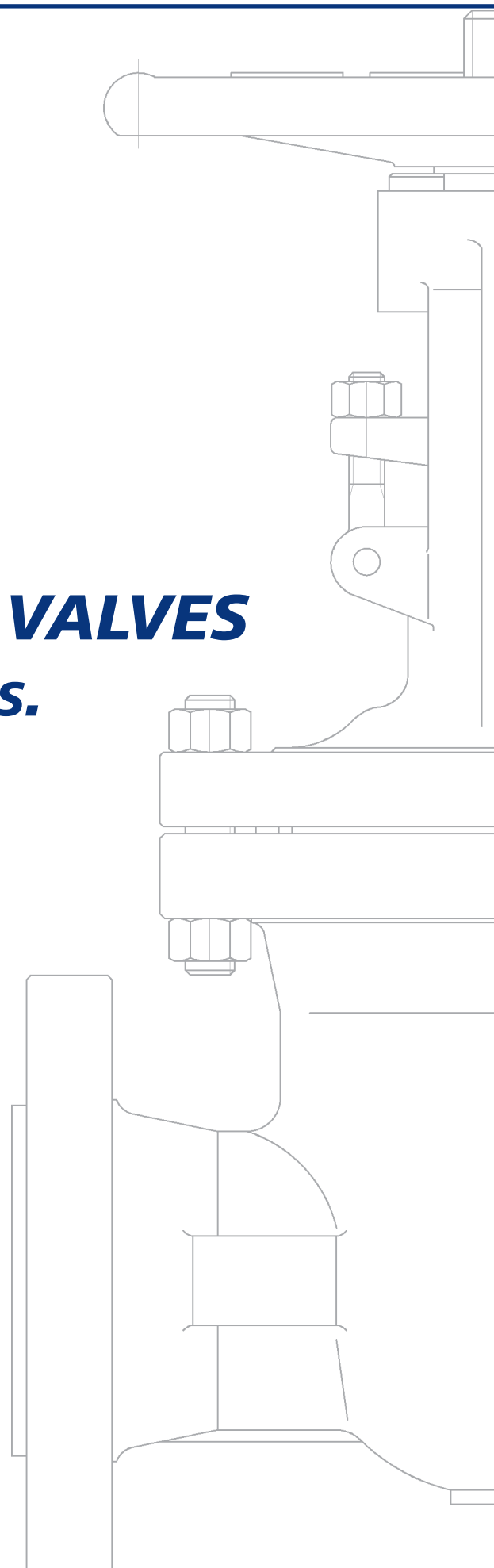

DESCRIPTION AND FEATURES

BOLTED BONNET
OUTSIDE SCREW AND YOKE (OS&Y)
RISING STEM
NON RISING HANDWHEEL
SOLID or FLEXIBLE WEDGE
RENEWABLE SEATS
<i>on request : ISO 5210 TOP FLANGE, LOCKING DEVICE,...</i>
<i>SEE DERVAL'S SPECIAL FEATURES FOR FURTHER EXECUTION</i>

GENERAL DESIGN SPECIFICATIONS

Design	ASME B16.34 / API600 / BS1414 / ISO 10434
Face to Face	ASME B16.10
End Flange	ASME B16.5 (2" ~ 24") ASME B16.47 (≥ 26")
BW Ends	ASME B16.25
Test	API 598 / API 6D / BS 6755 / EN 12266
Marking	MSS-SP25 / CE P.E.D. (97/23/EC)
Special	NACE MR 01.75 - 01.03 / ATEX 94/9/EC

MAXIMUM ALLOWABLE NON-SHOCK WORKING PRESSURE:

T (°C)	-29 ~ 38	50	100	150	200	250	300	350	375	400	425
P (Bar)	102,1	100,2	92,8	90,5	87,6	83,4	77,5	73,9	72,9	69,0	57,5

STANDARD MATERIAL OF PARTS

ITEM	PART NAME	MATERIAL
01	Body	ASTM A216 Gr.WCB
02	Seat Rings	Stellite Gr. 6 Faced
03	Wedge	ASTM A216 Gr.WCB+13Cr Faced
04	Stem	ASTM A182 F6a
05	Gasket *	Soft Iron Ring Joint
06	Bonnet	ASTM A216 Gr. WCB
07	Bonnet Bolt Nuts	ASTM A194 Gr. 2H(M)
08	Bonnet Bolts	ASTM A193 Gr. B7(M)
09	Backseat Bushing	ASTM A276 Type 410
10	Stem Packing *	Braided Graphite & Die Formed Graphite Ring
11	Eye Bolts Pins	Carbon Steel
12	Gland Eyebolt	ASTM A193 Gr. B7(M)
13	Gland	ASTM A276 Type 410
14	Gland Flange	ASTM A216 Gr. WCB
15	Eye Bolt Nuts	ASTM A194 Gr. 2H(M)
16	Grease Nipple	Carbon Steel
17	Stem Nut	ASTM A439 Gr. D-2 / ASTM B148 9A
18	Retaining Nut	Carbon Steel
19	Handwheel	Steel
20	Handwheel Nut	Carbon Steel
21	Screw	Carbon Steel
22	Yoke	ASTM A216 Gr. WCB
23	Yoke Pan Bolt Nuts	ASTM A194 Gr. 2H(M)
24	Yoke Pan Bolts	ASTM A193 Gr. B7(M)
25	Bearing	Steel
26	Lantern Ring <i>On Request</i>	ASTM A276 Type 410

* Recommended Spare Parts

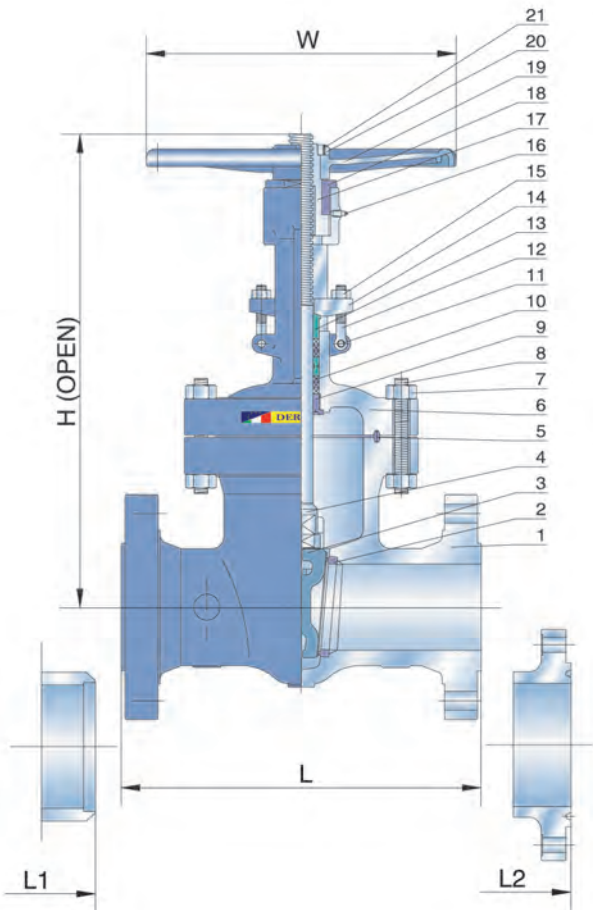

YOKE

FOR 8" & LARGER

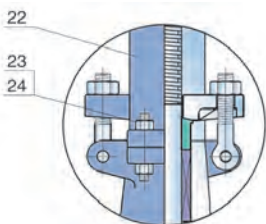

BALL BEARING

FOR 6" & LARGER

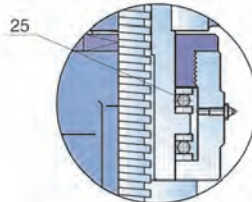

LANTERN RING

ON REQUEST

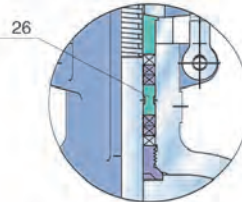

GEAR OPERATOR

RECOMMENDED FOR 10" & LARGER
STANDARD FOR 14" & LARGER

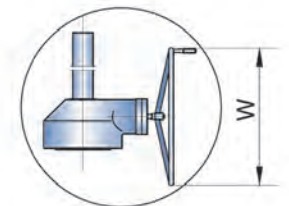

SIZE	mm	50	65	80	100	150	200	250	300	300	400	450	500	600	700	750	800	900
	inches	2"	2 1/2"	3"	4"	6"	8"	10"	12"	14"	16"	18"	20"	24"	28"	30"	32"	36"
L (RF)	mm	292	330	356	432	559	660	787	838	889	991	1092	1194	1397	1549	1651	1778	2083
L1 (BW)	inches	11,50	13,00	14,00	17,00	22,00	26,00	31,00	33,00	35,00	39,00	43,00	47,00	55,00	61,00	65,00	70,00	82,00
L2 (RTJ)	mm	295	333	359	435	562	664	791	841	892	994	1095	1200	1407	1562	1664	1794	2099
	inches	11,625	13,125	14,125	17,125	22,125	26,125	31,125	33,125	35,125	39,125	43,125	47,25	55,375	61,50	65,50	70,625	82,625
H (OPEN)	mm	455	538	550	690	910	1065	1257	1468	1623	1816	2260	2705	3100	3430	3800	4120	4380
	inches	17,91	21,18	21,65	27,17	35,83	41,93	49,49	57,80	63,90	71,50	88,98	106,50	122,05	135,04	149,61	162,20	172,44
W	mm	250	250	250	350	450	500	640	680	600	600	600	600	800	800	800	800	800
	inches	10	10	10	14	18	20	26	27	24	24	24	24	32	32	32	32	32
WEIGHT (RF)	Kg.	45	55	75	127	275	485	754	936	1316	1672	2070	2405	4000	6200	8000	10000	15000
WEIGHT (BW)	Kg.	40	47	64	105	213	380	660	830	1012	1217	1760	2000	3600	5500	7200	9200	14000

CAST STEEL GATE VALVE STANDARD MATERIALS OF PARTS (ASTM)

The following tables suggest standard combination of body / bonnet materials and trim (seat, stem, disc or wedge) composition. Different composition are available upon request

ITEM	PART NAME	CARBON STEEL		ALLOY STEEL						STAINLESS STEEL			
		TEMPERATURE (°C)	-29 - 427 °C	-46 - 343 °C	-29 - 468 °C	-29 - 593 °C	-29 - 593 °C	-29 - 649 °C	-29 - 649 °C	-196 - 816 °C	-196 - 816 °C	-196 - 427 °C	-196 - 454 °C
1	Body	A216 WCB	A352 LCB	A217 WC1	A217 WC6	A217 WC9	A217 C5	A217 C12	A351 CF8	A351 CF8M	A351 CF3	A351 CF3M	
2	Seat Ring (1)	A 182 F6a	A182 F304	A 182 F6a	A 182 F6a	A 182 F6a	A 182 F6a	A 182 F6a	A182 F304	A182 F316	A182 F304L	A182 F316L	
3	Wedge (2)	A216 WCB	A352 LCB	A217 WC1	A217 WC6	A217 WC9	A217 C5	A217 C12	A351 CF8	A351 CF8M	A351 CF3	A351 CF3M	
4	Stem	A 182 F6a	A182 F304	A 182 F6a	A 182 F6a	A 182 F6a	A 182 F6a	A 182 F6a	A182 F304	A182 F316	A182 F304L	A182 F316L	
5	Gasket	CL150-300	304(L)+Graphite	316(L) + Graphite				316(L) + Graphite					
		CL600-2500 Ring Joint	304(L)	316(L)				316(L)					
6	Bonnet	A216WCB	A352LCB	A217 WC1	A217 WC6	A217 WC9	A217 C5	A217 C12	A351 CF8	A351 CF8M	A351 CF3	A351 CF3M	
7	Bonnet Bolt Nuts	A194 2H	A194 Gr.4	A194 Gr.4	A194 Gr.4	A194 Gr.4	A194 Gr.4	A194 Gr.4	A194 Gr.8	A194 Gr.8M	A194 Gr.8	A194 Gr.8M	
8	Bonnet Bolts	A193 B7	A193 L7	A193 B16	A193 B16	A193 B16	A193 B16	A193 B16	A193 B8	A193 B8M	A193 B8	A193 B8M	
9	Backseat Bushing	A276 410	A276 304	A276 304	A276 304	A276 304	A276 304	A276 304	A276 304	A276 316	A276 304L	A276 316L	
10	Stem Packing	Braided Graphite & Die Formed Graphite Ring		Braided Graphite & Die Formed Graphite Ring				Braided Graphite & Die Formed Graphite Ring					
11	Eye Bolt Pins	Carbon steel		A276 410				Stainless Steel					
12	Gland Eye Bolts	A193 B7	A193 L7	A193 B16	A193 B16	A193 B16	A193 B16	A193 B16	A193 B8	A193 B8M	A193 B8	A193 B8M	
13	Gland	A276 410	A276 304	A276 410				A276 316					
14	Gland Flange	A216 WCB	A352 LCB	A217 WC1	A217 WC6	A217 WC9	A217 C5	A217 C12	A351 CF8	A351 CF8M	A351 CF3	A351 CF3M	
15	Eye Bolt Nuts	A194 2H	A194 Gr.4	A194 Gr.4	A194 Gr.4	A194 Gr.4	A194 Gr.4	A194 Gr.4	A194 Gr.8	A194 Gr.8M	A194 Gr.8	A194 Gr.8M	
16	Grease Nipple	Carbon steel		Alloy steel				Stainless Steel					
17	Stem Nut	A439 D2C / B148 9A		A439 D2C / B148 9A				A439 D2C / B148 9A					
18	Retaining Nut	Carbon steel		Alloy steel				Stainless Steel					
19	Handwheel	Steel		Steel				Steel					
20	Handwheel Nut	Carbon steel		Alloy steel				Stainless Steel					
21	Screw	Carbon steel		Alloy steel				Stainless Steel					
22	Yoke	A216 WCB	A352 LCB	A217 WC1	A217 WC6	A217 WC9	A217 C5	A217 C12	A351 CF8	A351 CF8M	A351 CF3	A351 CF3M	
23	Yoke Pan Bolt Nuts	A194 2H	A194 Gr.4	A194 Gr.4	A194 Gr.4	A194 Gr.4	A194 Gr.4	A194 Gr.4	A194 Gr.8	A194 Gr.8M	A194 Gr.8	A194 Gr.8M	
24	Yoke Pan Bolts	A193 B7	A193 L7	A193 B16	A193 B16	A193 B16	A193 B16	A193 B16	A193 B8	A193 B8M	A193 B8	A193 B8M	
25	Bearing	Steel		Steel				Steel					
26	Lantern Ring On Request	A276 410	A276 304	A276 304				A276 304	A276 316	A276 304L	A276 316L		

(1): Base material shall be at least equal in corrosion resistance to the body material (Acc. to API 600 Std.)

(2): Base material only. See trim material for wedge surface

Stainless Steel: At temperatures over 538°C, use the material only when the carbon contents is 0.04% or higher.

Derval S.r.l. reserves the right to substitute materials listed above with alternative material approved for designated service

TRIM MATERIALS (API 600 STANDARD)

The API TRIM N° 8 is supplied on Derval Valves as standard trim. Materials for other trims are in accordance with the following table. Other trims also according to customer's requirement.

TRIM N°	1	2	5	8	9	10	11	12	13	14	15	16	17
DERVAL DESCRIPTION	F6	304	F6-HF	F6-HFS	Monel	316	Monel-HFS	316-HFS	Alloy 20	Alloy 20-HFS	304-HF	316-HF	347-HF
2 Seat Surface	13Cr.	304	HF	HF	Monel	316	HF	HF	Alloy 20	HF	HF	HF	HF
3 Wedge Surface	13Cr.	304	HF	13Cr.	Monel	316	Monel	316	Alloy 20	Alloy 20	HF	HF	HF
4 Stem	F6	F304	F6	F6	Monel	F316	Monel	F316	Alloy 20	Alloy 20	F304	F316	F347
9 Backseat Bushing	F6	304	F6	F6	Monel	316	Monel	316	Alloy 20	Alloy 20	304	316	347

Note: The chart above only lists out some common composition of steel gate valve parts. We may provide other different parts material composition according to the customer's request or based on the actual valve working condition.

PRESSURE - TEMPERATURE RATINGS

The following pressure-temperature charts are derived from ASME B16.34. They will cover the most commonly used body and bonnet materials in the industry. All Derval Valves are designed to operate through the pressure and temperature ranges shown in these charts for a particular ASME Class Rating and ASTM Material.

Pressure temperature ratings are based on ASME B16.34 (bar/°C)
ASTM GROUP MATERIAL STANDARD - TO ASME B16.34

ASME 600

SERVICE TEMPERATURE °C	ASTM MATERIALS											
	Group 1.1	Group 1.3	Group 1.5	Group 1.9	Group 1.10	Group 1.13	Group 1.14	Group 2.1	Group 2.2	Group 2.1	Group 2.2	
	A216 WCB(a)	A352 LCB(b)	A217 WC1(c)	A217 WC6(d)	A217 WC9(e)	A217 C5	A217 C12	CF8(e)	CF8M(e)	CF3(f)	CF3M(g)	
WORKING PRESSURES (bar)												
-29 to 38	102,1	95,7	95,8	103,4	103,4	103,4	103,4	99,2	99,3	99,2	99,3	
50	100,2	94,6	95,3	102,3	102,4	103,4	103,4	95,7	96,3	95,7	96,3	
100	92,8	90,2	93,2	97,5	98,1	103,1	103,1	81,8	84,4	81,8	84,4	
150	90,5	87,9	89,8	92,7	93,3	100,4	100,4	72,7	77,0	72,7	77,0	
200	87,6	85,4	88,4	91,0	89,7	97,6	97,6	65,5	71,3	65,5	71,3	
250	83,4	81,2	86,2	88,9	88,4	92,7	92,7	61,1	66,8	61,1	66,8	
300	77,5	75,4	84,1	84,9	84,9	84,9	84,9	58,1	63,3	58,1	63,3	
350	73,9	71,9	80,5	80,5	80,5	80,5	80,5	56,1	60,8	56,1	60,8	
400	69,0	-	73,2	73,2	73,2	73,2	73,2	54,9	58,2	54,9	58,2	
425	57,5	-	70,2	70,2	70,2	69,0	70,2	54,3	57,3	54,3	57,3	
450	40,1	-	67,6	67,6	67,6	61,8	67,6	53,7	56,2	53,7	56,2	
500	17,6	-	48,1	55,6	55,6	40,5	55,0	52,1	53,7	-	53,7	
525	10,4	-	30,1	40,5	43,8	30,8	45,2	47,8	52,6	-	-	
540	6,5	-	21,4	25,5	32,7	23,4	34,0	43,6	49,9	-	-	
600	-	-	-	11,8	15,3	13,1	14,4	33,4	42,9	-	-	
650	-	-	-	4,6	7,3	6,0	7,0	21,0	28,2	-	-	
700	-	-	-	-	-	-	-	12,0	19,9	-	-	
750	-	-	-	-	-	-	-	7,3	11,0	-	-	
800	-	-	-	-	-	-	-	4,1	7,0	-	-	
(Hydr.) Shell Test	153,2	143,6	143,7	155,1	155,1	155,1	155,1	148,8	149,0	148,8	149,0	
(Hydr.) Seat Test	112,3	105,3	105,4	113,7	113,7	113,7	113,7	109,1	109,2	109,1	109,2	
(Pneum.) Seat Test	5,5	5,5	5,5	5,5	5,5	5,5	5,5	5,5	5,5	5,5	5,5	

- a) Permissible, but not recommended for prolonged usage above 427°C (800°F)
- b) Not to be used over 343°C (650°F)
- c) Permissible, but not recommended for prolonged usage above 468°C (875°F)
- d) Not to be used over 593°C (1100°F)

- e) At temperature over 538°C (1000°F), use only when carbon content is 0,04 or higher
- f) Not to be used over 427°C (800°F)
- g) Not to be used over 454°C (850°F)

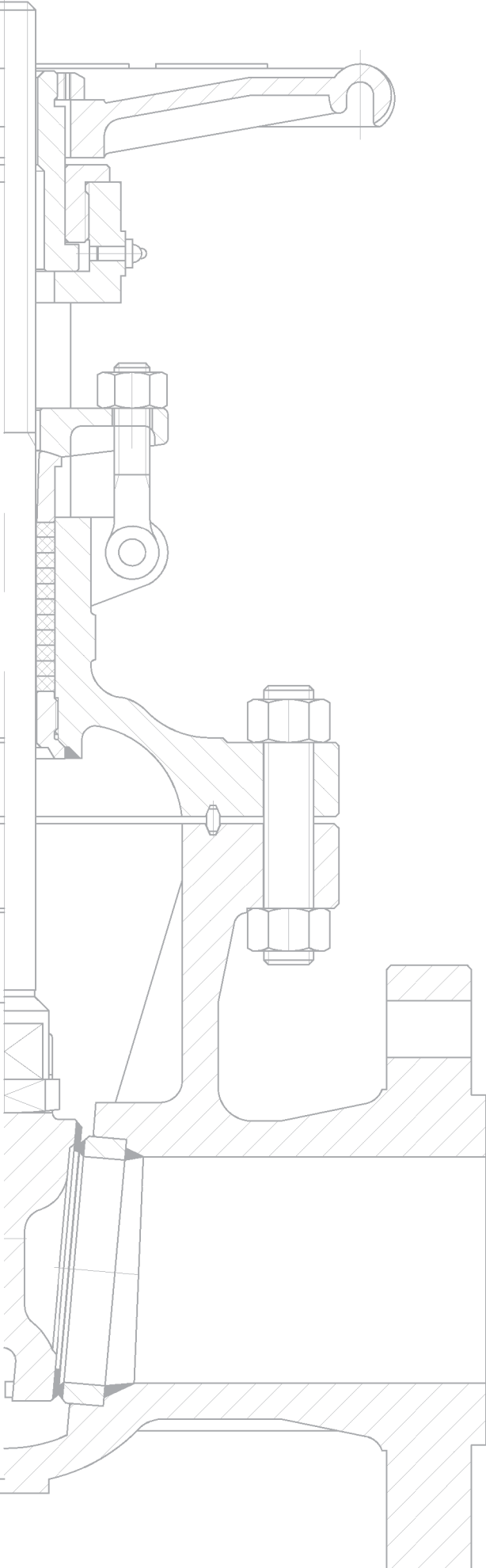

APPLICATION:

Derval gate valves are used as efficient shut-off valves with flow in either direction for water, saturated steam, air, gas, oil and crude oil products. They are utilized in applications where minimum pressure drop is necessary.

Due to their specific design, gate valves should be operated in the full-open or full-close position. Concentrated flow across the seats of a partially opened gate valve risks possible seat damage, therefore throttling is not recommended.

Operating parameters are in accordance with ASME B16.34 standard.

INSTALLATION:

Derval gate valves are normally installed in horizontal pipe with vertical stem (handwheel up).

The high quality Derval valves are installed in a large variety of services in the Oil & Gas field, Chemical and Petrochemical industry, in On-shore and Off-shore drilling/refining, Power Generation, Water and Wastewater Treatment industries.

 **DERVAL** s.r.l.

DERVAL S.R.L.

VIA GUIDO ROSSA, 13

20024 GARBAGNATE MILANESE

(MILANO) - ITALY

PHONE: +39 02 990.20.302

FAX: +39 02 990.25.461

WEB: www.derval.it

E-MAIL: info@derval.it